



TNGG160-50Hz

Engine: TG170G5VTA86

Fuel: natural gas

Basic characteristic

Generator sets TEDOM ranks among medium capacity machines, based on gas engines burning natural gas, biogas, LPG, mine gases, accompanying gases from oil extraction, syngas and pyrolysis gases. Power range of this series is from 80 to 210 kW. The basic version of genset contains: engine-generator, complete cooling system, complete air intake, exhaust silencer and electrical panel with power and control parts. The combustion engine is completely controlled by the engine management BOSCH specially designed for TEDOM Inc., which provides ignition control, richness of the filling mixture, speed control and optimizes the engine run and thus helps to reduce the fuel consumption.

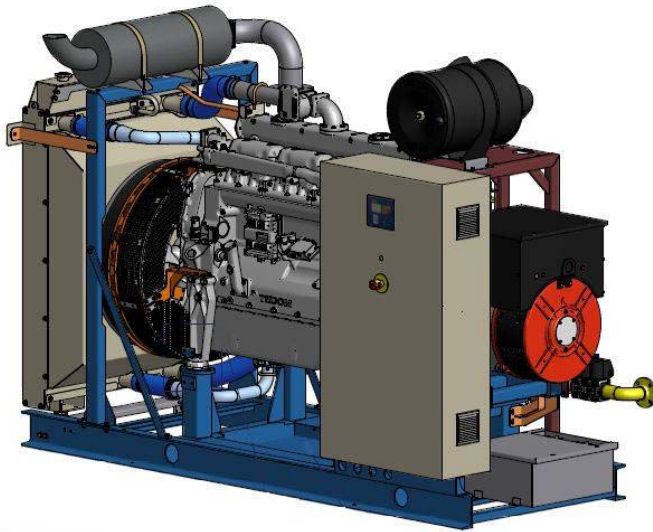

Options for extending.

- ✓ Automatic oil filing.
- ✓ Automatic pre-heating of engine
- ✓ Water cooling (plate heat exchangers) with emergency radiators
- ✓ Stainless steel exhaust line
- ✓ Sound cover
- ✓ Installation in container
- ✓ ATS panel for SPE mode.
- ✓ Primary regulator of gas pressure
- ✓ Remote control

Design	TNGG160 - basic
Operation	SP,SPI – synchronous, parallel with mains, island
Fuel	natural gas

Basic technical data

Nominal electric output	SI : 140 kW / 175 kVA	SP : 160 kW / 200 kVA
Nominal heat output *	252 kW	
Fuel input	461 kW	
Electric efficiency	34,7 %	
Heat efficiency*	54,6 %	
Total efficiency (fuel use) *	89,3 %	
Fuel consumption at 100% of output	48,2 m ³ /h	
Fuel consumption at 75% of output	36,6 m ³ /h	
Fuel consumption at 50% of output	26,1 m ³ /h	

Requested minimal continuing electric output is 50% of nominal output
 Gas consumption is mentioned at invoicing conditions (15°C, 101,325 kPa)
 Automatic regulation of mixture richness.
 * is valid only for modification as cogeneration unit, with exhaust cooling to 120°C

**Engine: TEDOM TG 170 G5V TA 86.**

Number of cylinders	6
Cylinders arrangement	In line
Bore x Stroke	130 x 150 mm
Displacement	11946 cm ³
Compression ratio	12 : 1
Speed	1500 min ⁻¹
Oil consumption normal / max.	0,3/0,5 g/kWh
max. output of engine	170,6 kW

Specification TEDOM TG170G5VTW86 rev. F_18.9.2013

Fuel

Heating power	34 MJ/m ³
min. methane number	80
Gas pressure	2 × 10 kPa
max. change of gas pressure at changes of consumption	10 %
max. temperature	30 °C

Technical data mentioned in this specification are valid for natural gas with parameters given up.

Besides natural gas it is possible to use other gases (e.g. propane, biogas, landfill gas). In that case contact the producer. Input gas line contains set of two independent quick-closing electromagnetic valves for gas inlet closing at unit stop, zero regulator of gas pressure and metal hose for connection to mixer. Generator set correct operation gas connection with correct dimension and adequate accumulative volume is required (preventing before gas pressure decrease in period of jump in gas consumption) ended by hand gas closer and equipped by pressure gauge.

Generator : LEROY SOMER LSA 46.2

cos φ	1,0
Efficiency in working point	95,8 %
Voltage	400 V
frequency	50 Hz

Electrical parameters

Nominal voltage	230/400 V
Nominal frequency	50 Hz
Power factor	0,8L±0,8C
Nominal current at cos φ=0,8	288 A
Generator circuit breaker	NR400F 3P
Switchboard short-circuit resistivity	25 kA
Own source contribution to short-circuit current	< 3 kA
Power switchboard protection closed / opened	IP 32/00
Control switchboard protection closed / opened	IP 32/20
Recommended superior circuit breaker	400 A
Recommended connection cable ** (< 50m, at t<35°C)	CYKY 3×150 +70

** Listed cable is only for information, it's necessary to perform check calculation of temperature rise and voltage drop according to real length, placing and cable type (max. allowed voltage drop is 10 V)



Emission limit

	CO	NOx
emission (at 5%O ₂ in exhaust gas)	650mg/Nm ³	500mg/Nm ³

* to comply the high emissions CO, Generator set can be equipped by oxidative catalyzer

Installation information

Non-usable heat radiated into surrounding area	25 kW
Quantity of combustion air	741 m ³ /h
Quantity of ventilation air	7,03 m ³ /s
Temperature of sucked air min / max	10/35 °C

Non-usable heat (radiated from hot parts of the Generator set) is radiated from unit into surrounding air of machine room. With respect to local conditions of machine room (size, heat loss) it is necessary to propose the air exchange in machine room

Exhaust gas quantity	785 m ³ /h
Exhaust gas temperature nom. / max.	595/621 °C
Max. back-pressure behind machine	20 mbar
Max. back-pressure delivered exhaust silencer	10 mbar
Max. back-pressure connection pipe after exhaust silencer	10 mbar

The delivery may be included exhaust silencer, which will connect to exhaust gas outlet. Exhaust gas line from Generator set flange to flue pipe must be tight. Exhaust gas line must have downgrade in direction from the unit.. Material of exhaust gas line and thermal isolation of exhaust gas line in machine room must be resistant to temperatures up to 200°C.

TNGG200 in 1 m	98 dB(A)
----------------	----------

Noise parameters indicate level of acoustic pressure, measured in free acoustic field

Quantity of lubrication oil in engine	56 dm ³
Quantity of lubrication oil in oil tank for refilling	70 dm ³

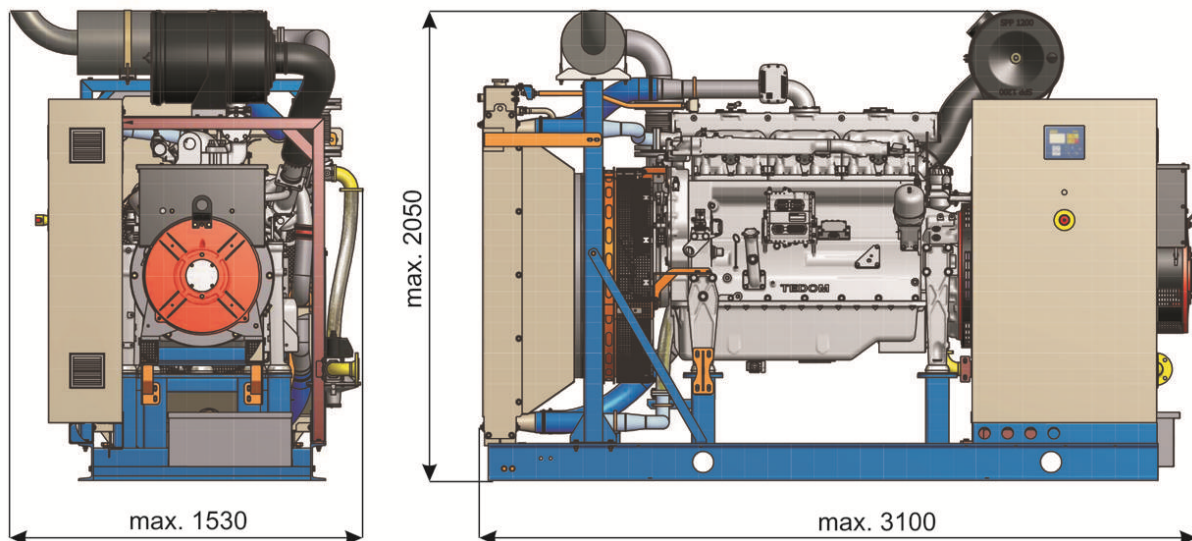

Weight	2750 kg
--------	---------

TEDOM a.s. reserves the privilege to change this document and consequential documents!